



NU6-II Low-voltage Surge Arrester

1. General

- 1.1 Certificates: international certificates are under proceeding;
- 1.2 Number of poles: 1, 2,3, 4;
- 1.3 Electric ratings: 230/400V, AC50Hz;
- 1.4 Application: Protect electric system and on-loading electrical apparatus from thunder and instantaneous over-voltage;
- 1.5 Standard: IEC 61643-1, EN 61643-11



2. Technical data

Model	Max. continuous operational voltage U_c (V~)	Level of protection U_p (kV)	Maximum discharge current I_{max} (8/20 μ s) (kA)	Nominal discharge current I_n (8/20 μ s) (kA)	Mounting category of protected apparatus
NU6-II	385	1.8	40	15	II, III
	460	2.0			II, III
NU6-II	385	1.8	60	25	II, III
	460	2.0			II, III
NU6-II	385	1.8	100	40	II, III
	460	2.0			III

Auxiliary contact	Configurations	Rated voltage U_n (V)	Rated current I_n (A)
	INO+INC	AC125	3

3. How to select surge protectors

- a. The voltage should be $\leq U_c$;
- b. $U_p <$ maximum impulse withstands;
- c. Different protectors should be selected according to various grounding system and protection mode.

Model	Max. continuous operational voltage U_c (V~)	Applicable grounding system	Protection mode	Circuits	Number of poles
NU6-II	385	TN-S	L-PE, N-PE, L-N	1 phase, 3 phase 5 wire	1,2,3,4
		TN-C	L-PE	1 phase, 3 phase 4 wire	1,2,3
		TT	L-PE, N-PE, L-N, L-L	1 phase, 3 phase 4 wire	1,2,3,4
	460	TN-S	L-PE, N-PE, L-N, L-L	1 phase, 3 phase 5 wire	1,2,3,4
		TN-C	L-PE, L-L	1 phase, 3 phase 4 wire	1,2,3
		IT	L-PE, N-PE, L-L	1 phase, 3 phase 3 /4 wire	1,2,3,4
		TT	L-PE, N-PE, L-N, L-L	1 phase, 3 phase 4 wire	1,2,3,4



4. Functions

- 4.1 The product is composed of two independent components: removable protective module 4 and base 2;
- 4.2 When the product is damaged, the part 3 will indicate; please replace the removable protective module 4 at once and there is no need to cutoff the circuits;
- 4.3 The part 1 is for maximum continuous operational voltage indication as well as avoiding replacement with wrong module.

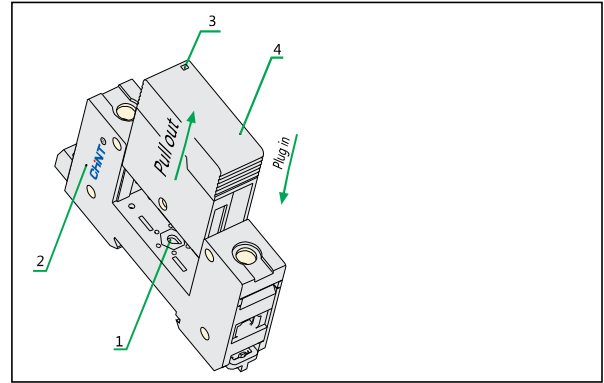

NU6-II/F (40, 60kA) with remote control port

5. Overall and mounting dimensions (mm)

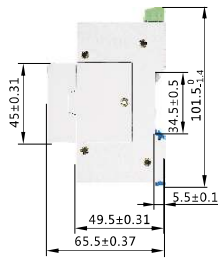

← Auxiliary contact

NU6-II (40, 60kA) without remote control port

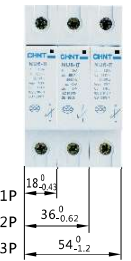
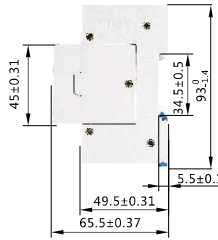

NU6-II/F (100kA) with remote control port

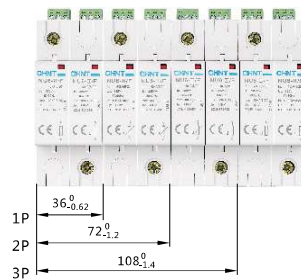
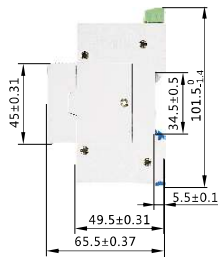

← Auxiliary contact

NU6-II/F (100kA) without remote control port

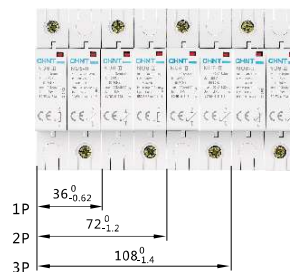
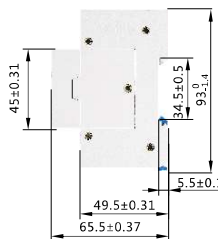



NU6-III Low-voltage Surge Arrester

1. General

- 1.1 Certificates: international certificates are under proceeding;
- 1.2 Electric ratings: Single phase power distribution and control system of AC50Hz, 230V;
- 1.3 Short circuit current: up to 5kA (8/20μs);
- 1.4 Application: Protect electric system and on-loading electrical apparatus from lightning and instantaneous over-voltage;
- 1.5 Standard : IEC61643-1, EN61643-11



2. Technical data

Model	Uoc (1.2/50μs) (kV)	Short circuit current Isc (8/20us)(KA)	Max. continuous operational voltage Uc (V~)	Level of protection Up (kV)
NU6-III	10	5	275	1.5
			320	1.5
			385	1.5

Auxiliary contact	Configurations	Rated voltage Un(V)	Rated current In(A)
contact	INO+INC	AC125	3

3. Type and circuit diagram

Model	Type	Circuit diagram
NU6-III	1P+N 	Compound Type
	2P 	Compound Type



4. Design type and protective mode of different surge protectors

Model	Uoc (1.2/50μs) (kV)	Uc (V~)	Corresponding design type and protection mode
NU6-III	10	275	Compound type (with gasdischarge tube + voltage sensitive resistance) L-N/N-PE
		320	Compound type (with gas discharge tube + voltage sensitive resistance) L-PE/N-PE
		385	

5. Functions

- 5.1 The product is composed of two independent components: removable protective module 4 and base 2;
- 5.2 When the product is damaged, the part 3 will indicate; please replace the removable protective module 4 at once and there is no need to cutoff the circuits;
- 5.3 The part 1 is for maximum continuous operational voltage indication as well as avoiding replacement with wrong module.

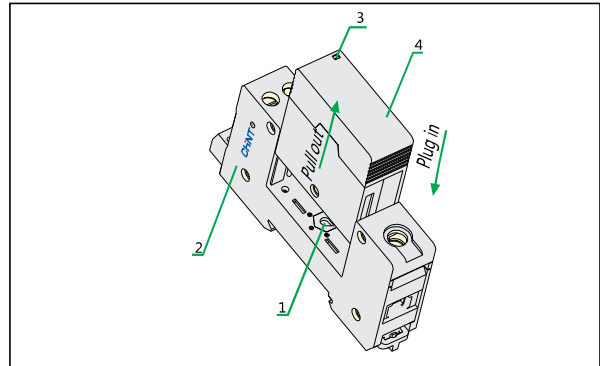

NU6-III/F with remote control port

6. Overall and mounting dimensions (mm)

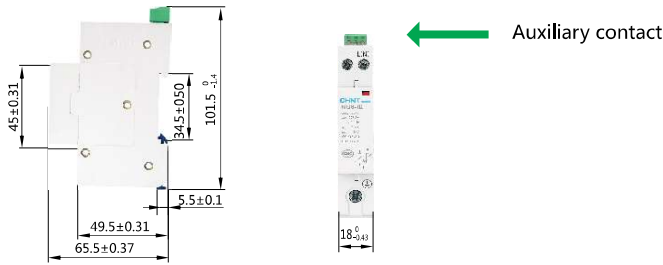

NU6-III without remote control port



NU6-II series surge arrester	NU6-III series surge arrester
The boundary between lightning protection areas of LPZ1 & LPZ2	The boundary between lightning protection areas of LPZ2 & LPZ3
Protection category: C	Protection category: D
Over-voltage mounting category: II	Over-voltage mounting category: I
Rated impulse withstand voltage: 2500V	Rated impulse withstand voltage: 1500V
Parameters of discharge: I _{max} and I _n	Parameters of discharge: U _{oc} and I _{sc}
Applicable to branch power distribution switchgear	Applicable to terminal of power distribution



*Note: Fuse/Circuit breaker are strongly recommended to be installed upstream the surge protector.

7. Recommended circuit breaker selection

Surge protector	Maximum discharge current (kA)	Fuse or circuit breaker (upstream)
NU6-II	40	gL/gG 125A
	60	gL/gG 160A
	100	gL/gG 250A
NU6-III	ALL	NB1 C10